

THE RECORD PLAYER

Super Groove Precision Tonearm



PRELIMINARY

User & Setup Manual

General Use

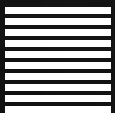

VERTERE™

Introduction

Thank you for your purchase of the Super Groove precision Tonearm. Please study these instructions carefully. Your SG Tonearm is designed and manufactured to the highest standards and its correct installation will greatly enhance the sound quality of your record playing system rewarding you with many years of listening pleasure.

Guarantee

Your Vertere Super Groove Tonearm is guaranteed against any defect in materials and workmanship for a period of two years from the date of purchase. You can extend this period to **ten years** by registering your warranty on the Vertere website - vertereacoustics.com

Make a note of the serial number(s) on your warranty card for future reference - please retain the card

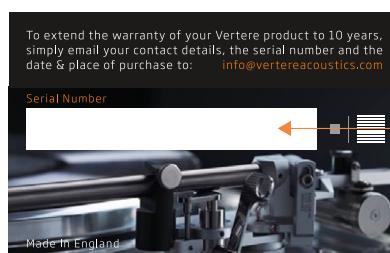

Serial Number(s)

This guarantee excludes:

1. Damage caused due to accident, misuse, neglect and incorrect installation, adjustment or repair.
2. General wear & tear.
3. Liability for damage or loss during transit from the retailer or purchaser to Vertere or its authorised distributor for the purposes of repair or inspection.

Carriage costs to Vertere shall be borne by the consignee.

All claims under this guarantee must be made through an authorised Vertere retailer.

If equipment returned for repair to Vertere is found on inspection to comply with the product specification Vertere reserves the right to make a charge for examination and return carriage.

There are no user serviceable parts inside your Vertere Super Groove Tonearm.

Unauthorised servicing will void this guarantee.



Maintenance & Cautions

IMPORTANT

After clipping the arm in, placing the stylus guard on and switching the amplifier off the tone arm may be cleaned with a lightly dampened soft cloth or soft brush.

Take extreme care not to damage the cartridge stylus, anti-skate weight/thread or the tone arm tri-pivot bearing by applying excessive force on any of the parts.

Do not undo or tighten any of the screws which are indicated as 'Not User Serviceable Part' in the following pages.

Do not apply undue force on any of the user adjustable screws or parts.

Avoid using abrasives or solvents on your Super Groove tonearm.

Unpacking

Your Super Groove Precision Tonearm comes packed with:

- 1 Main Counterweight
- 2 Counterweight Locator
- 3 Main Tonearm
- 4 Pillar Holder & Fixing Nut
- 5 Alignment Protractor
- 6 Accessory Pack

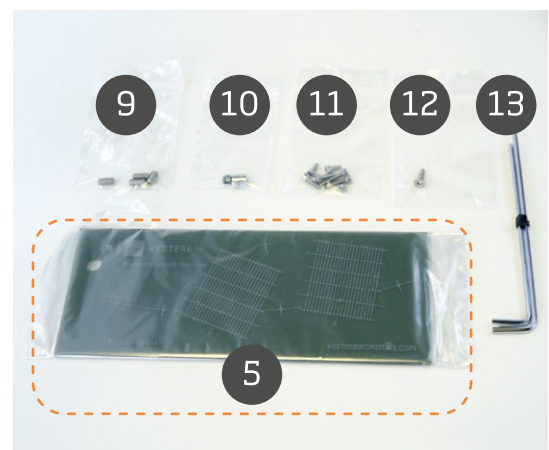
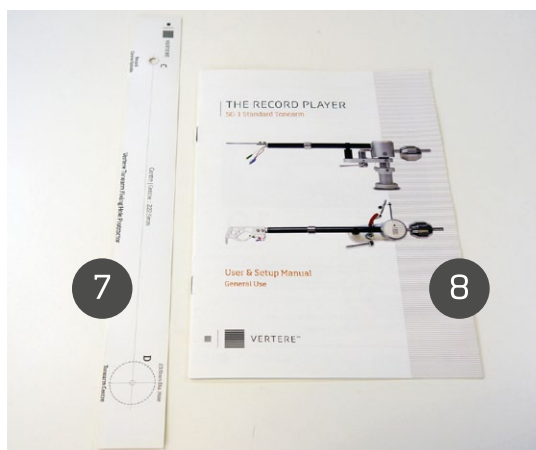
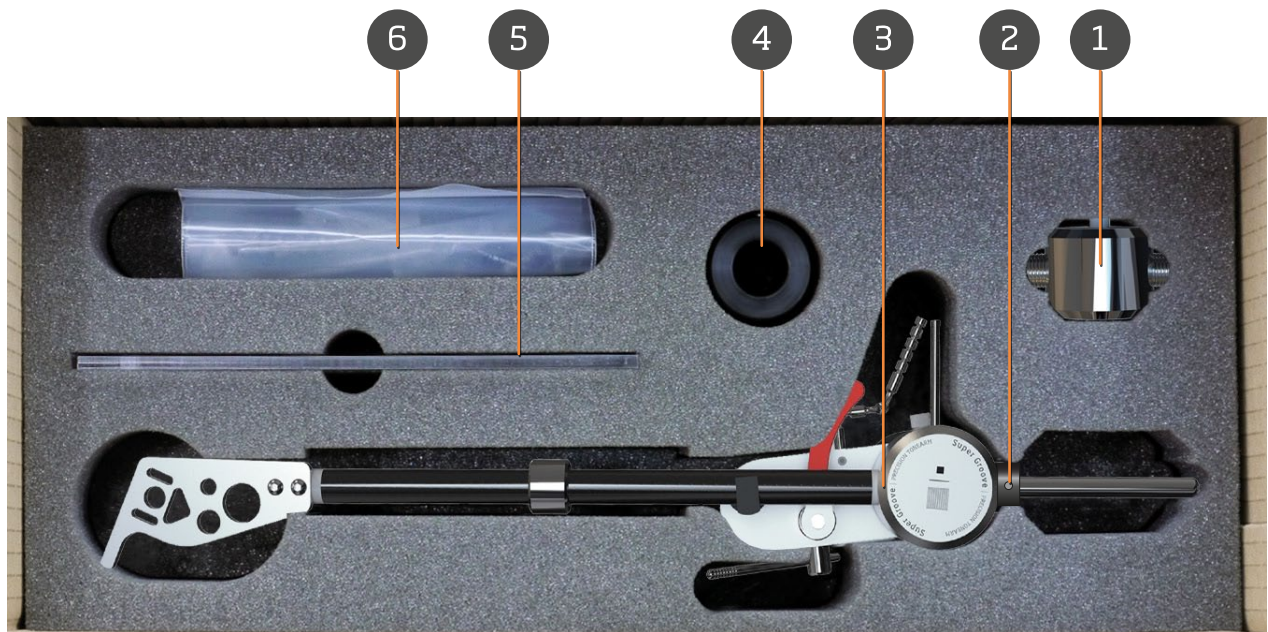

Accessory Pack

- 7 Arm Cut-out Protractor
- 8 Super Groove Tonearm User Manual
- 9 Pillar Holder & Fixing Nut Screws
- 10 Anti-skate Weight/Thread Assembly

- 11 Cartridge Fixing Screws
- 12 Bearing Yoke Screw -
To replace the Transit screw
- 13 Allen Key Set

Tri-Pivot Bearing Transit Protection **IMPORTANT**

After removing the arm from its packing tray, observe the bearing protection card and the bearing yoke transit screw which lift and fix the yoke separating the bearing point from the three silicon nitride balls to avoid any damage to the precision bearing during transit.

Its best to leave the protective card in place until after the cartridge and the counterweight have been fitted. This will avoid accidental damage to the bearing point and/or the silicone nitride balls.

Also observe the bearing yoke transit screw - marked red. This screw is fitted to inhibit the bearing yoke from moving sideways during shipping/transport and avoid the bearing point accidentally hitting the nitride balls and causing damage.

Bearing yoke Transit screw. Carefully undo to remove and replace with bearing yoke screw for general use.

NOTE:
For shipping, this Transit screw must be refitted - See below.

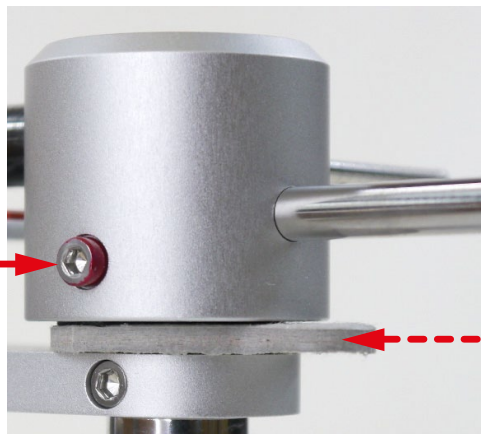

Slide protective card out for use or gently lift the bearing yoke and slide it into position for shipping or transportation.



Bearing Yoke Screw plus 2mm | 2.5mm Allen Keys.



Remove Bearing Yoke Transit Screw.

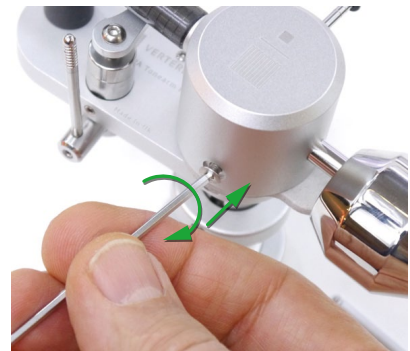

Replace with Bearing Yoke Screw for use.

IMPORTANT
DO NOT remove or adjust this screw.

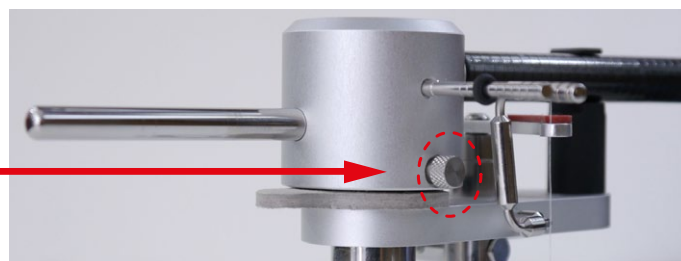

Unique Tri-Pivot Bearing & its protection during transit & shipping

It is important to understand how the unique Tri-Pivot bearing of the SG-1 is designed to operate in order to protect it against accidental damage.

Although this bearing may seem at first sight to be a uni-pivot, in fact its much more sophisticated and eliminates the unwanted 'skating' of a uni-pivot bearing. The Tri-Pivot Bearing of the SG-1 allows simple azimuth adjustment similar to a uni-pivot. The geometry of this bearing in operation however, behaves like a 'rigid' bearing tonearm thus combining the best of both worlds.

To prevent accidental damage to the Tri-Pivot Bearing, there is a Transit Screw and a Protective Card that should be fitted correctly before the tonearm is shipped.



Transit | Shipping

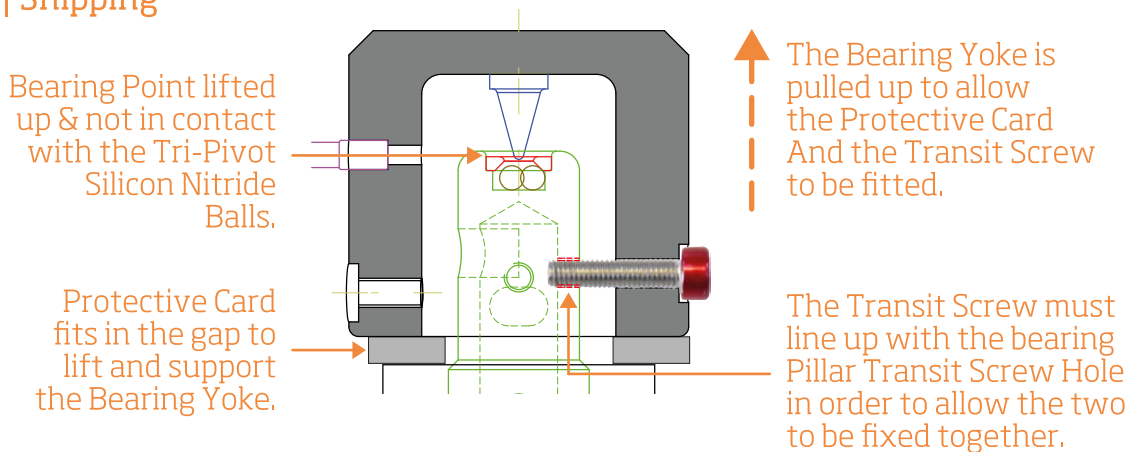

Operation | General Use

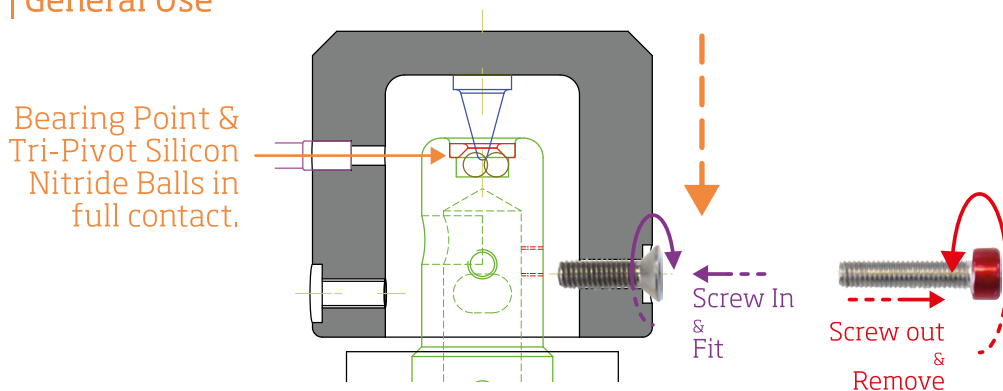

Tri-Pivot Bearing & its protection during transit & shipping

It is important to align and fit the Transit Screw as outlined below in order to protect the Tri-Pivot Bearing and to prevent any accidental damage.

Main Bearing Yoke & the Bearing Pillar must be positioned central to each other with the Transit Screw holes lined up before fitting the Transit Screw. See below



IMPORTANT
The Lift/Lower Plate And the Bearing Yoke must be centred as shown, before the Transit Screw is fitted.

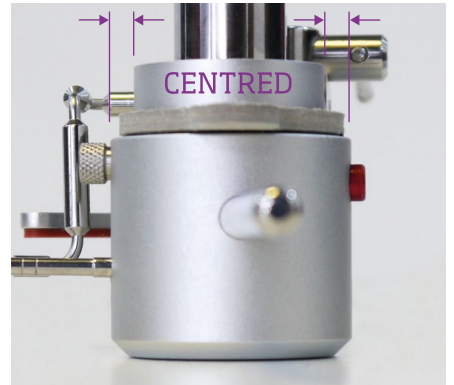

Tri-Pivot Bearing Safe

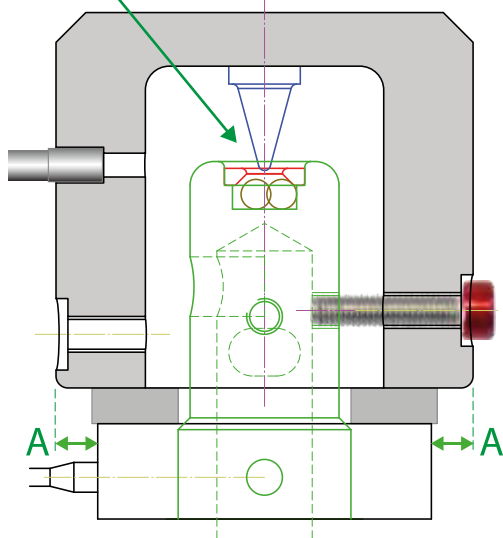

YOKE/BEARING CENTRED



Tri-Pivot Bearing Unsafe

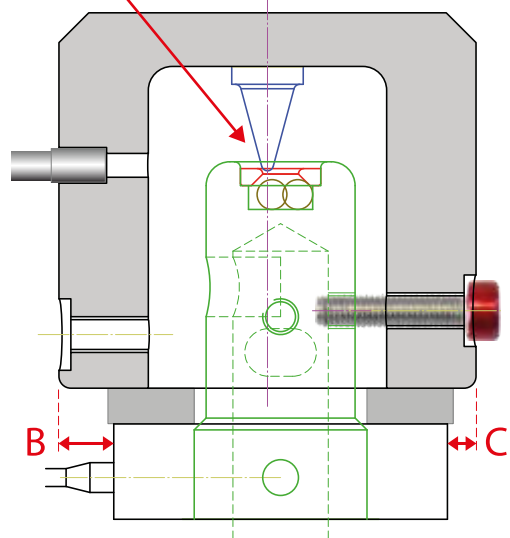

YOKE/BEARING NOT CENTRED



Using the Counterweight Locating Device for transit, shipping & setup

The Counterweight Locating Device is used as a positional reference to enable refitting the counterweight in the exact setup position after it has been removed for shipping or transit. This eliminates the need to setup the Tracking Weight & Azimuth again.

It's an accurate and easy way of ensuring the counterweight will be repositioned the same as it was initially setup. See below

Using a 1.5mm A/F Allen key, slightly loosen the Locator fixing screw to free the locator from its parked position and move it towards the fully 'setup' counterweight.

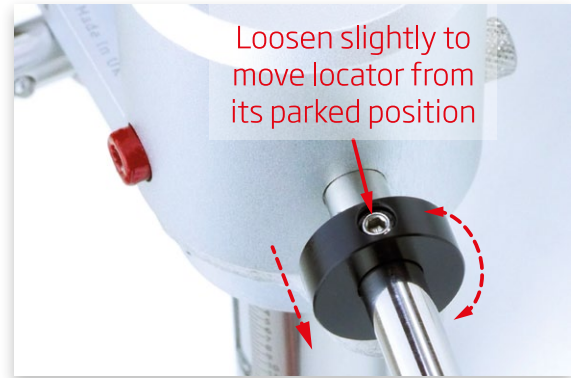

Once the pointed end of the locating screw touches the counterweight, gently rotate it until it fully locates into the Locator recess and stops still.

Holding the locator in position re-tighten the fixing screw on top.

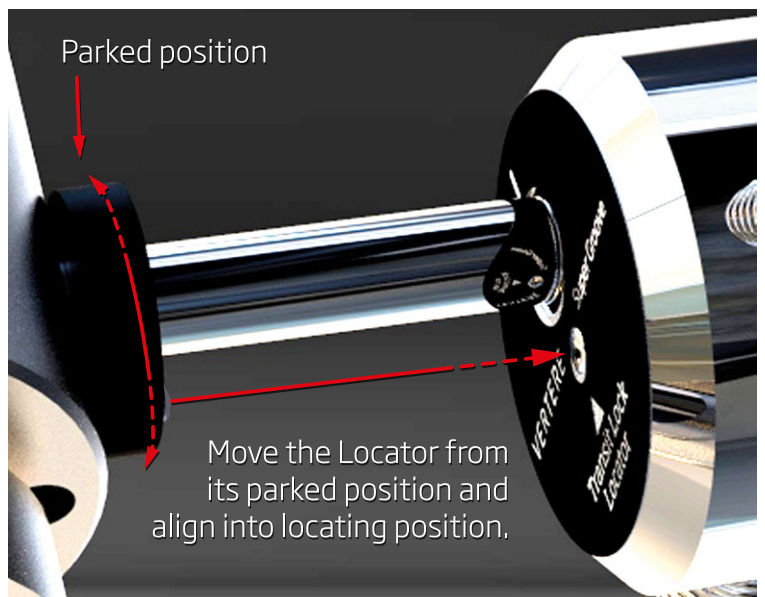

With the locator perfectly fixed in the setup position gently remove the counterweight from the peg.

NOTE:

Azimuth Fine Adjustment Screw lock is tightened to avoid accidental movement of the screw.

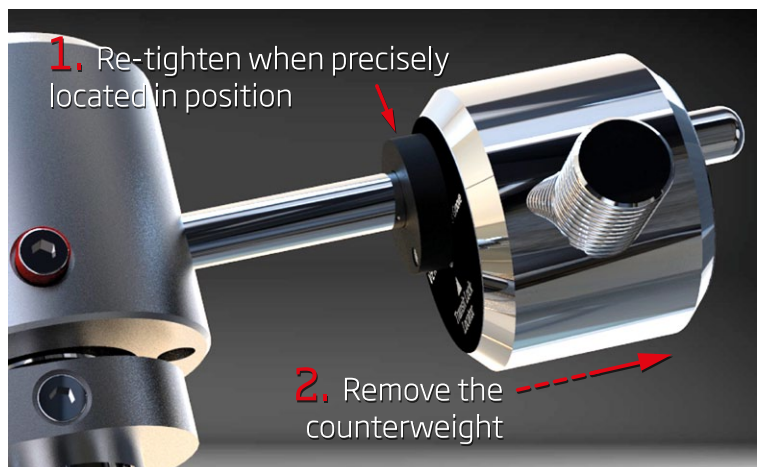

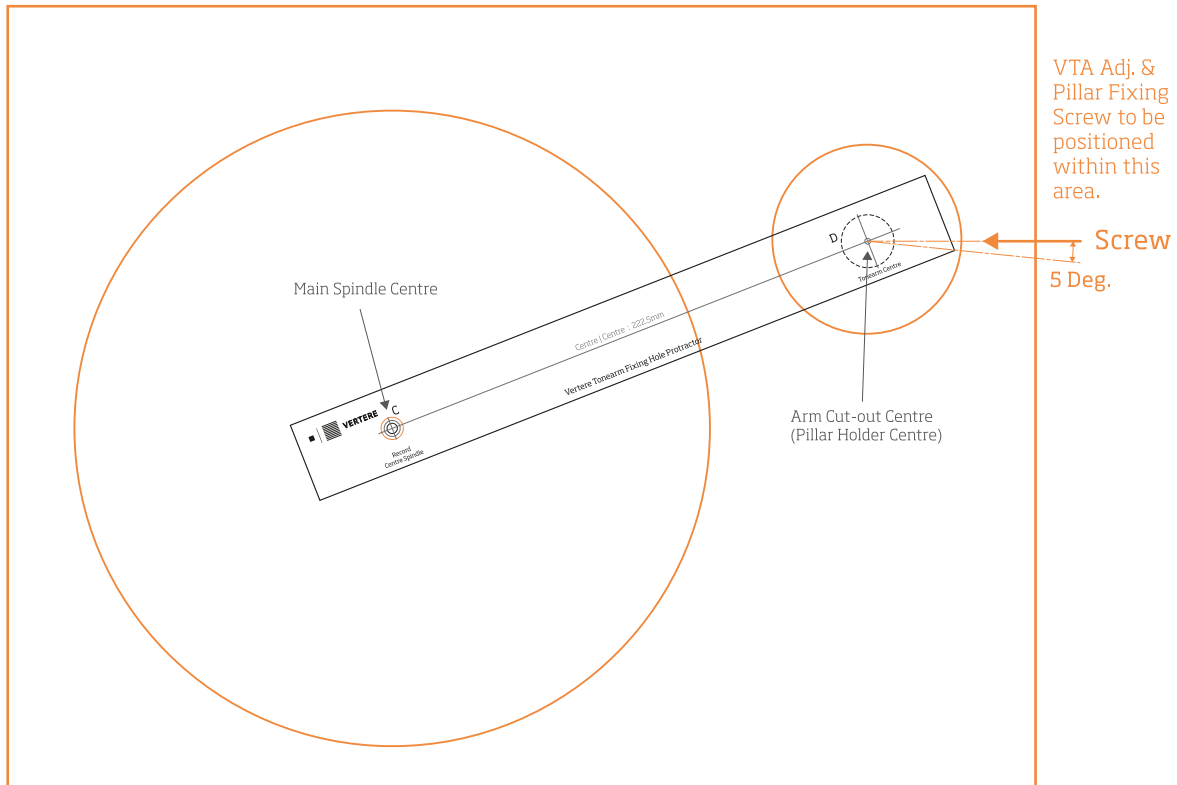

Fitting Instructions

Your Super Groove tonearm pillar holder should be fitted at 222.5mm from the main spindle centre. Using the tonearm fixing hole protractor, mark the centre of the arm pillar cut-out. Arm pillar holder cut-out hole diameter is 23mm. Use a suitable drill/cutter to cut this hole.

Please note any Rega/Roksan cut-out arm-board could also be suitable for your Super Groove tonearm.

Vertere RG-1/SG-1 record players are supplied with the corresponding SG-1 tonearm cut- out arm-boards as shown. Simply fit the arm pillar holder to the arm-board and tighten the fixing nut finger tight.

Make sure the three fixing grub screws are loose and not touching the arm board. These will later be used to finally fix the arm pillar holder to the arm-board.

Next fit the arm-board to the record player - use the fixing hole protractor to locate the arm pillar holder at exactly 222.5mm distance to the spindle centre. Tighten the arm-board to the record player, align the pillar fixing screw as shown, and tighten the three fixing grub screws to ensure rigid coupling of the arm pillar holder to the arm board.

NOTE

Tool required: 2.0mm A/F Allen Key - supplied

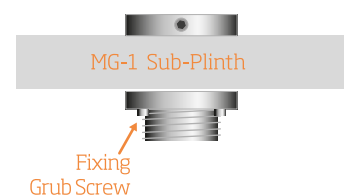

Overview

- 1 Aluminium Alloy Head-shell & Titanium for HB version
- 2 Roll Wrapped Carbon Fibre Arm Tube
- 3 Stainless Steel Effective Mass & Fine Tracking Weight Adjustment Ring
- 4 Machined Acetal Arm Clip

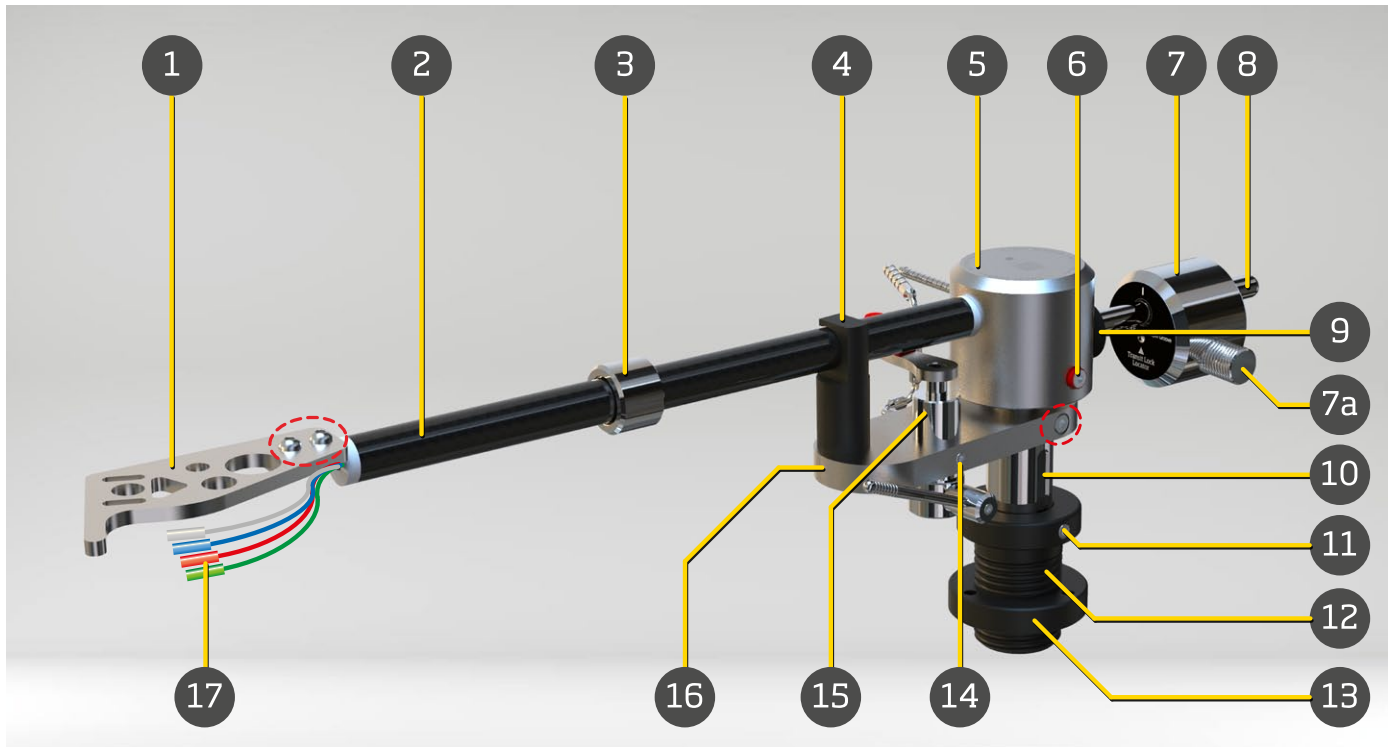

- 5 Aluminium Alloy Main Bearing Yoke
- 6 Bearing Protection Transit Screw
- 7 Chrome Plated Brass Main Counterweight
- 7a Azimuth Fine Adjustment Screw
- 8 Stainless Steel Counterweight Rod
- 9 Counterweight Locator | Transit
- 10 Chrome Plated Brass Main Pillar
- 11 VTA Adjustment & Pillar Fixing Screw
- 12 Acetal Pillar Mount
- 13 Acetal Pillar Mount Fixing Nut
- 14 L/L Mechanism Height Adjustment Screw
- 15 Stainless Steel Lift/Lower Mechanism
- 16 Aluminium Alloy Lift/Lower Plate
- 17 Lead Wires & Gold Plated Cartridge Tags
- 18 Anti-skate Rod
- 19 Anti-skate Bar
- 20 Anti-skate Weight/Thread Assembly

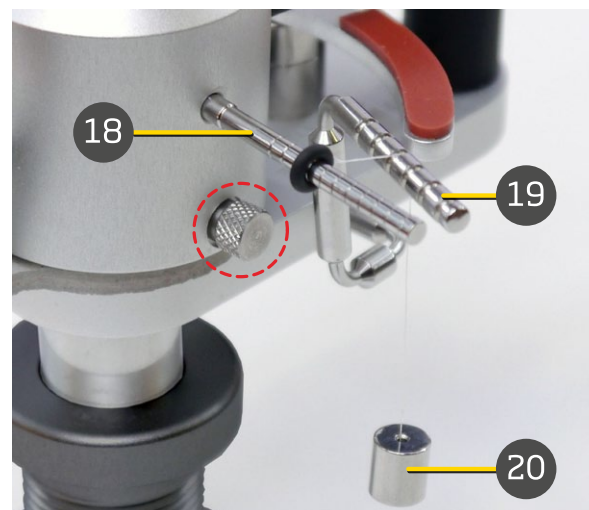

 : Not User Serviceable Parts - **Do Not** Undo or adjust These Screws

Fitting The Cartridge

Carefully hold the arm by the Main Pillar and leave the protective card in place for the time being to avoid damage to the Tri-Pivot Bearing.

Have the cartridge you are intending to fit at hand and leave its stylus guard on for extra protection.

Use the supplied high quality stainless steel cartridge fixing screws, and nuts if required to mount the cartridge onto the head-shell but do not fully tighten the screws just yet.

Take care to connect the cartridge tags correctly in accordance with the cartridge manufacturer's instructions.

Be especially careful handling the internal wiring of the tonearm when connecting to the cartridge pins.

The stylus tip should be set directly below the front edge of the head-shell and the body of the cartridge should be aligned parallel with the side edge. This way the alignment and the overhang would be almost done and ready to be checked using the supplied protractor.

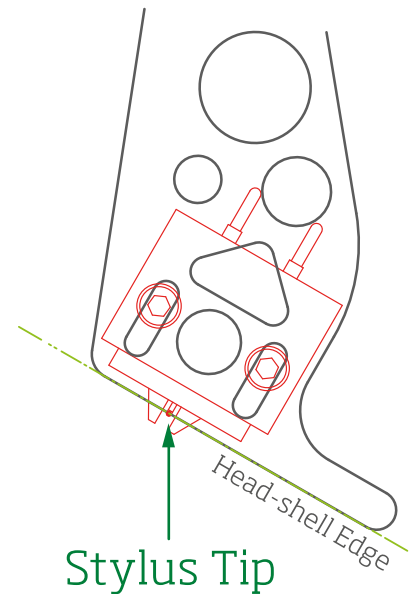

The tonearm can now be fitted to the arm pillar holder on the arm-board.

Please note at this point the counterweight is not yet fitted and the arm/cartridge should not be lowered onto the record, stylus balance or platter surface as this will damage the cartridge.

The VTA adjustment and pillar fixing screw should be undone sufficiently to allow the tonearm pillar to easily slide into the pillar holder. There is a VTA locating recess on the tonearm pillar which will line up with the VTA adjustment screw and also stops the tonearm from coming out of or dropping fully down into the arm pillar holder.

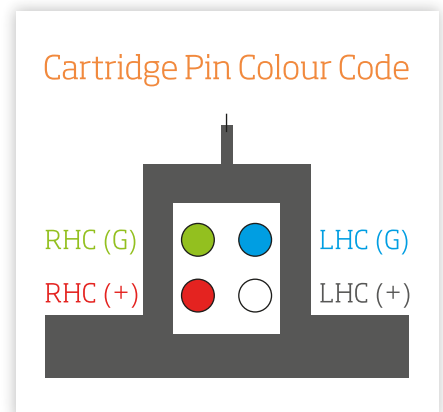

Locate the arm in a position where the arm tube is approximately parallel to the platter top surface - Almost correct VTA.

Now gently push the counterweight onto the counterweight peg with the main body of the counterweight hanging down as shown. The Counterweight has an off-centre hole and a sideways screw that allow fine Azimuth adjustment and added stability to the arm due to a lowered centre of gravity.

Now remove the protective card under the Bearing Yoke.

Using a stylus balance, set the tracking weight of the cartridge in accordance with manufacturer's instructions. Initially this should be carried out with the fine tracking weight adjustment ring in the middle of the arm tube. Later the ring can be used to fine-tune the tracking weight and the arm/cartridge resonance.

Please note that at this point the Anti-skate weight should also be fitted as this can influence the azimuth setting of the tonearm.

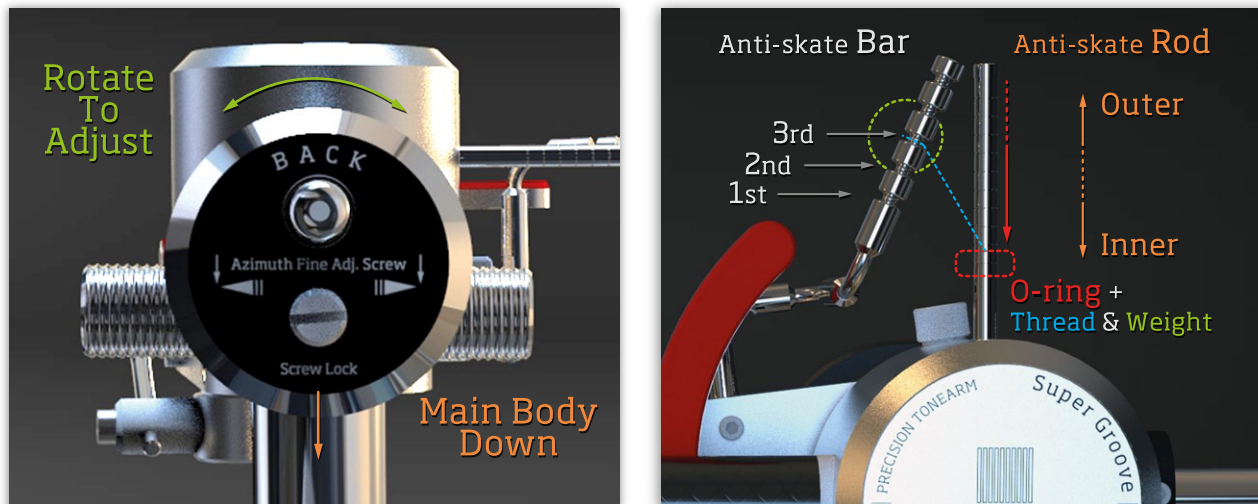

Tracking weight increases the closer the C/W is to the Bearing Yoke and decreases the further it is from the Bearing Yoke.

Cartridge Alignment

Cartridge azimuth must be set before you align the cartridge horizontal and vertical tracking angles. Correct azimuth is when the cartridge sits parallel to the record surface when viewed head on from the front - see below.

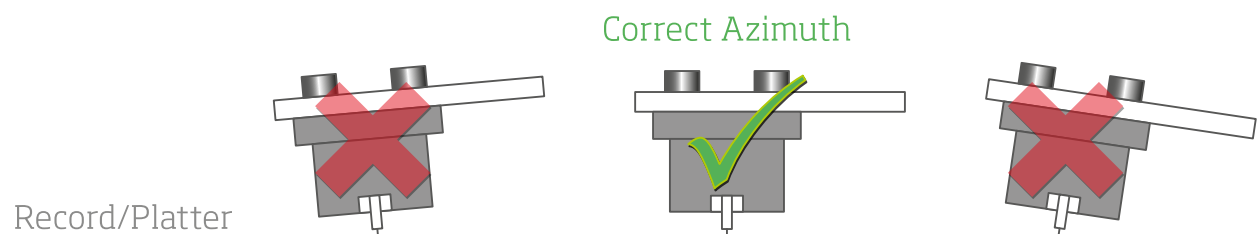

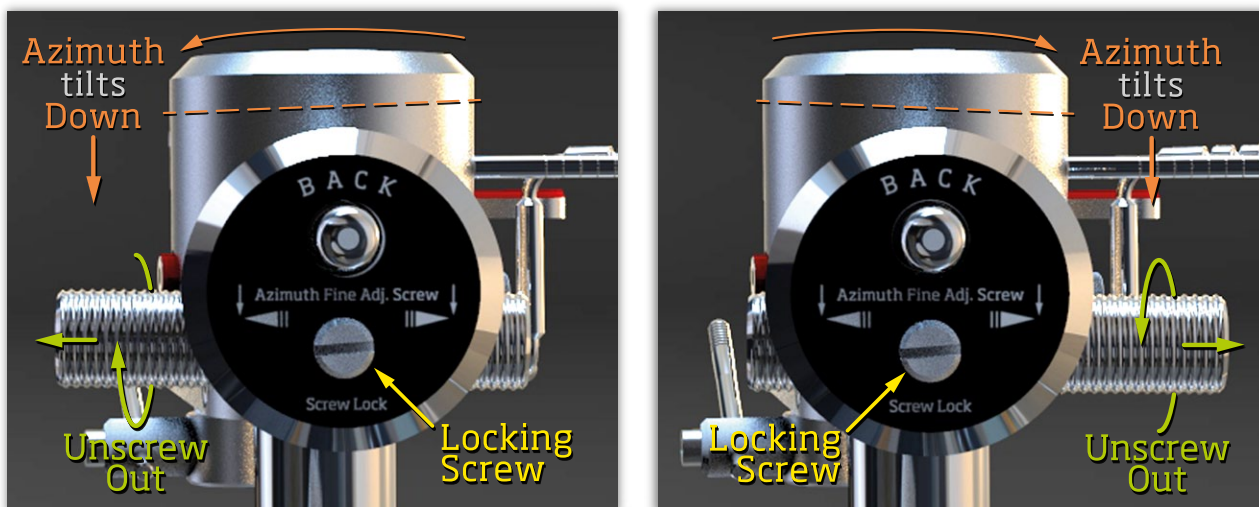

Adjust the azimuth by rotating the main counterweight which will in turn rotate the tonearm thus changing the azimuth. The head-shell/arm will tilt as shown as the Adjustment Screw unscrewed outwards. See illustrations

IMPORTANT

Undo the Locking Screw slightly to free the large Fine Adjustment Screw before turning it IN or OUT to adjust the azimuth. DO NOT alter the position of the counterweight while making this adjustment as it will change the tracking force - if in doubt recheck the tracking force.

Now place the alignment protractor provided onto the main spindle and carefully locate the arm/cartridge on it lining up the stylus tip with the marked stylus path arc as shown. When the cartridge is mounted in its correct position in the head-shell, the stylus tip will track along the marked stylus path and be aligned perfectly to the grid on A and B. See below.

Use the cartridge fixing screws to adjust the position of the cartridge achieve perfect alignment as this has a profound influence on the performance of the record player.

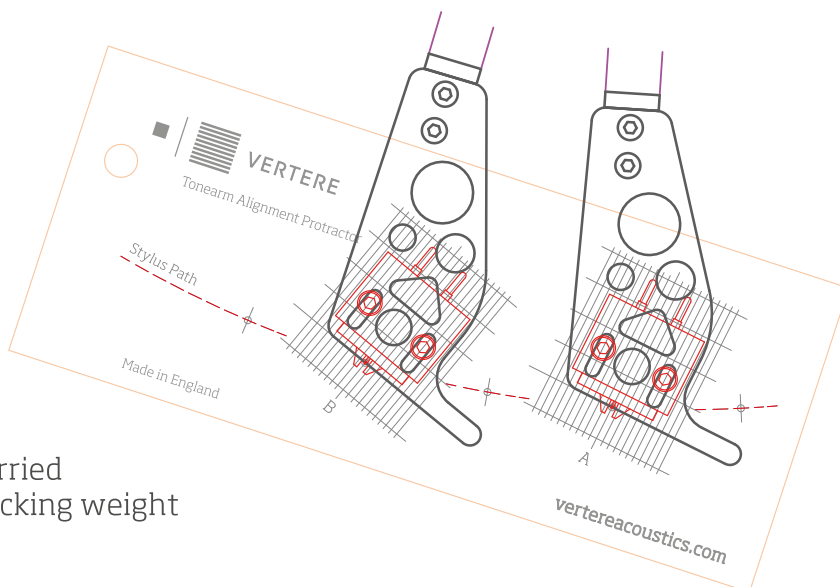

Once azimuth and cartridge alignments are successfully carried out, you can fine adjust the tracking weight and VTA.

VTA Adjustment

With the record player in stop mode, place a reasonably flat LP record on the platter/mat. Carefully lower the tonearm/cartridge and the VTA Alignment protractor provided on the record as shown below and check if the arm tube is parallel with the horizontal lines on the protractor. Using the VTA adjustment screw on the tonearm pillar holder, raise or lower the arm until the arm tube is parallel or just fractionally up at the back.

IMPORTANT: The arm must be lifted off the record and secured in the arm clip to avoid any damage to the stylus while raising or lowering it for this adjustment - see below.

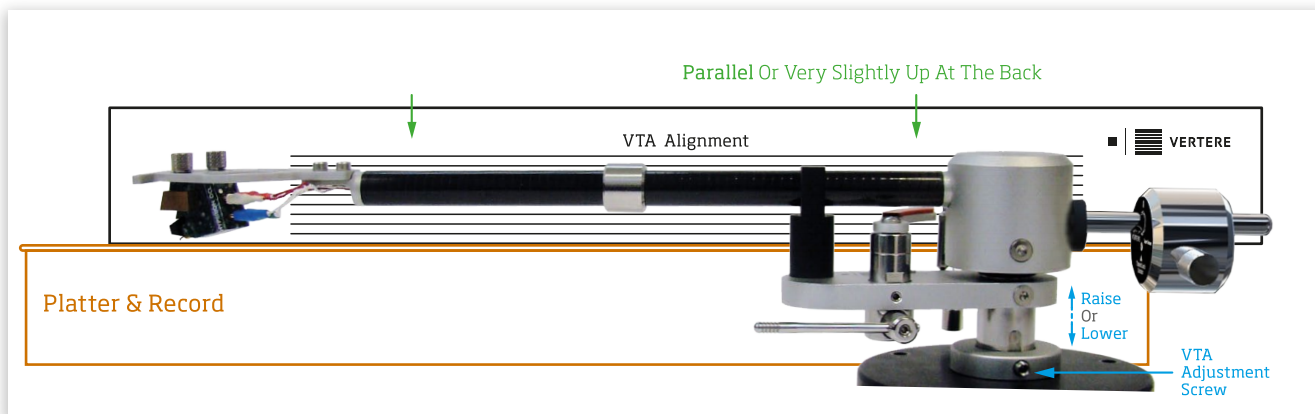

Arm/Cartridge Resonance

With most cartridges the arm/cartridge resonance should be between 8Hz - 12Hz. If due to cartridge weight and compliance this resonance goes outside this range, it should be possible to bring it within the range by simply repositioning the tracking weight sleeve and the main counterweight. As shown, by moving the ring towards the head-shell the main counterweight would also require to be moved away from the bearing yoke thus increasing the arm effective mass. This will in turn lower the arm/cartridge resonance frequency. And vice versa to raise the frequency.

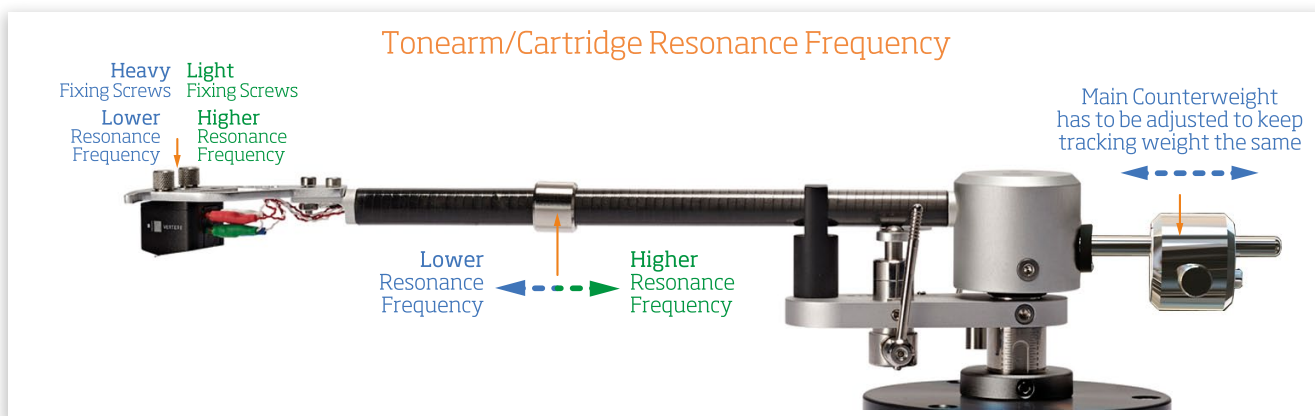

NOTE: To check and measure arm/cartridge resonance you require a test record with this facility recorded on it. If in doubt consult your retailer or Vertere.

Fine Tracking Weight Adjustment

With the record player in stop mode, place a stylus balance on the platter and check the cartridge tracking weight. Now fine adjust the tracking weight to manufacturer's recommendation by moving the ring slightly forward towards the head-shell to increase and back to decrease tracking weight - see below.

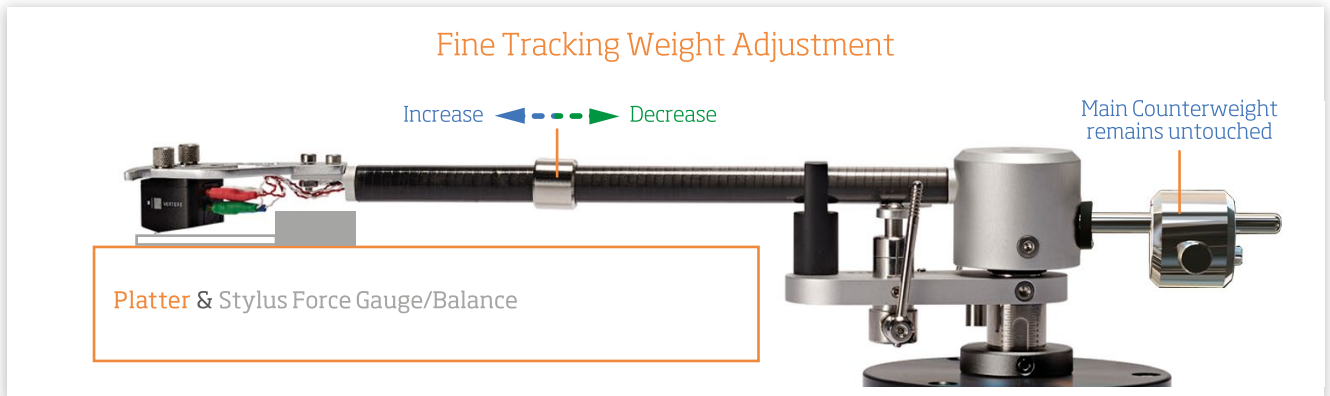

IMPORTANT: This procedure is for 'fine' adjustment only and the main counterweight should be used for general setting of the cartridge tracking weight.

Anti-skate 'Curve' Adjustment

The anti-skate bar has 5 thread runner grooves that allow alignment with the position of the anti-skate 'O' ring. The 'O' ring position increases the amount of anti-skate the further it is from the bearing yoke. Choose the runner groove for the thread according to the O-ring position, normally using the standard position - see below.

Finally check that the anti-skate force is set correctly by using a suitable test record.

Thread Runner Position	Anti-skate on record groove
1	Lower on the outer & higher on the inner
2	gradually becoming
4	Higher on the outer & lower on the inner

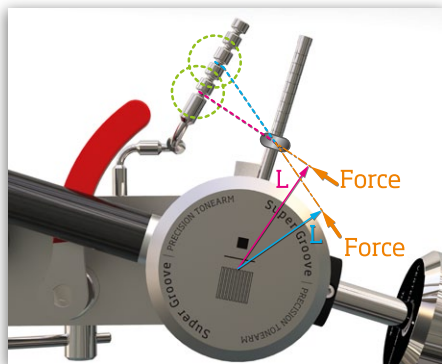
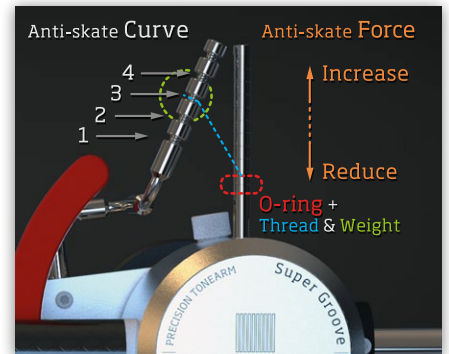

Outer Groove on record

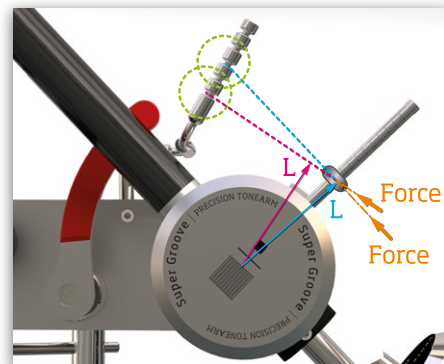

Inner Groove on record

Tonearm & Cartridge Setup

You can fit the phono cartridge now and setup the SG-1 tonearm by following the SG-1 Tonearm and the cartridge manufacturer's User Manual.

It is important to set the tracking weight first before doing any further adjustments.

Some set-up tips for SG-1 Tonearm;

Always use the Vertere Alignment Protractor to set the tonearm up correctly.

To check azimuth and VTA use the Vertere Azimuth | VTA Alignment Block or a suitable a parallel sided small block - for example a square sided spirit level. See Accessories on Vertere website.

Place the Cartridge on the alignment protractor provided and using the Azimuth/VTA block, set the tonearm to the correct position.



Place the Block as shown and view the cartridge/head-shell from the front. Adjust following the SG-1 Tonearm Instructions until the azimuth is correct.

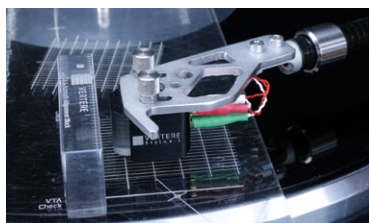

Place the Block as shown and view the cartridge/head-shell from the side. Adjust following the SG-1 Tonearm Instructions until the VTA is correct.

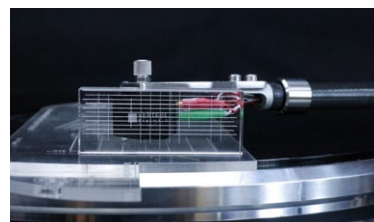
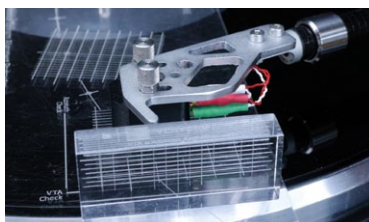

Having set the tracking force, VTA & azimuth, check that the Anti-skate Bar and Rod are inline and that the Anti-skate Thread is **parallel** with the main yoke as shown. Note the Bar can be adjusted by gently rotating and/or bending it as required to become in line with the Anti-skate Rod. See below.

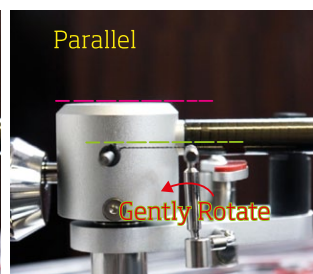
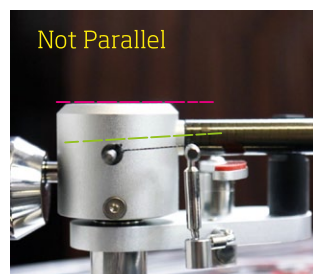
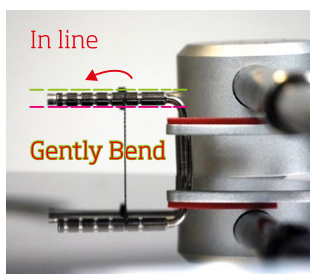
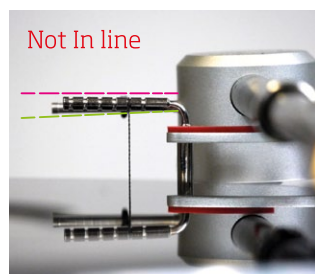

IMPORTANT:

Do not attempt this setup if you are in any doubt or you do not have the tonearm or the cartridge user manual. Contact your Vertere retailer, distributor or Vertere for assistance.



VERTERE™

RECORD PLAYING SYSTEMS

RG-1 Reference Groove Record Player
SG-1 Super Groove Record Player
MG-1 **MkII** Magic Groove Record Player
DG-1 Dynamic Groove Record Player

MOTOR DRIVES

RG-1 Reference Motor Drive
imperium Precision Motor Drive
Tempo Precision Motor Drive

TONEARMS

Vertere Reference Tonearm **New Gen.**
SG-1 **MkII** Tonearm PULSE-HB Internal Wiring
SG-1 **MkII** Tonearm Standard PULSE Internal Wiring

PHONO CARTRIDGES

Mystic Moving Coil Cartridge
s a b r e HD Moving Magnet Cartridge
Magneto Moving Magnet Cartridge

PHONO PREAMPLIFIER

PHONO-1 **MkII**

ANALOGUE INTERCONNECT CABLES

PULSE-HB
PULSE-**veRum**
PULSE-**Redline**
D-Fi
RCA, XLR Balanced, DIN & 5-Pin Tonearm

SPEAKER CABLES

PULSE-HB
PULSE-XS Reference
PULSE-XS
PULSE-**Redline**
7mm, 4mm Banana & Spade - Single Ended Or Bridged Balanced

DIGITAL INTERCONNECT CABLES

PULSE-HB
PULSE-**Redline**
D-Fi
USB TypeA, TypeB, Mini, Micro, Ethernet RJ45
COAX-75 Ohm RCA & BNC, AES/EBU Balanced XLR

MAINS POWER CABLES & DISTRIBUTION

PULSE-HB, PULSE-HBS & HB MAINS DISTRIBUTION BLOCK
PULSE-**Redline**
UK, EU, US: IEC & IEC 20A

RECORD PLAYER SUPPORT

STAGE-1 REFERENCE ISOLATION PLATFORM

EQUIPMENT SUPPORT

STAND-1 REFERENCE EQUIPMENT SUPPORT



5 Oliver Business Park Oliver Road London NW10 7JB UK
T +44 (0)20 3176 4888 E info@vertereacoustics.com

vertereacoustics.com

Printed In England

All specifications are liable to change without prior notice. E & OE